

Gasoline Engine Owner's Manual

EX20D

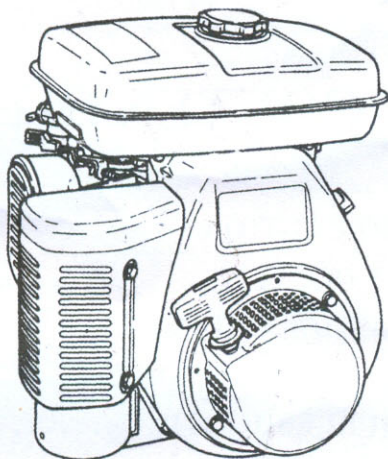

Keep this owner's manual handy, so you can refer to it at any time.

This owner's manual is considered a permanent part of the engine and should remain with the engine if resold.

The information and specifications included in this publication were in effect at the time of approval for printing.

READ THIS OWNER'S MANUAL CAREFULLY. Pay special attention to these symbols and any instructions that follow:

▲ DANGER Indicates serious injury or death will result if instructions are not followed.

▲ WARNING Indicates a strong possibility that serious injury or death could result if instructions are not followed.

▲ CAUTION Indicates a possibility that minor injury or an result if instructions are not followed.

NOTICE Indicates that equipment or property damage can result if instructions are not followed.













NOTE: Gives helpful information.

If a problem should arise, or if you have any questions about your engine, consult your engine dealer.

CONTENTS

1. SYMBOLS	1
2. SAFETY PRECAUTIONS	2
3. COMPONENTS	5
4. PRE-OPERATION CHECKS	6
5. OPERATING YOUR ENGINE	7
6. EASY TROUBLESHOOTING	10
7. MAINTENANCE SCHEDULE	12
8. "HOW-TO" MAINTENANCE	13
9. PREPARATIONS FOR STORAGE	16

1. SYMBOLS

	<p><i>Read the owner's manual.</i></p>		
	<p><i>Stay clear of the hot surface.</i></p>		
	<p><i>Exhaust gas is poisonous. Do not operate in an unventilated room.</i></p>		
	<p><i>Stop the engine before refueling.</i></p>		
	<p><i>Fire, open light and smoking prohibited.</i></p>		
	<p><i>On (Run)</i></p>		<p><i>Plus ; Positive polarity</i></p>
	<p><i>Off (Stop)</i></p>		<p><i>Battery</i></p>
	<p><i>Engine oil</i></p>		<p><i>Engine start (Electric start)</i></p>
	<p><i>Add oil</i></p>		

2. SAFETY PRECAUTIONS

▲WARNING Please make sure you review each precaution carefully.

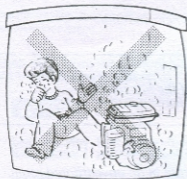

EXHAUST PRECAUTIONS

- Never inhale exhaust gasses. They contain carbon monoxide, a colorless, odorless and extremely dangerous gas which can cause unconsciousness or death.
- Never operate the engine indoors or in a poorly ventilated area, such as tunnel, cave, etc.
- Exercise extreme care when operating the engine near people or animals.
- Keep the exhaust pipe free of foreign objects.

REFUELING PRECAUTIONS

- Be sure to stop the engine prior to refueling.
- Do not overfill the fuel tank.
- If fuel is spilt, wipe it away carefully and wait until the fuel has dried before starting the engine.
- After refueling, make sure that the fuel cap is secured to prevent spillage.



FIRE PREVENTION

- Do not operate while smoking or near an open flame.
- Do not use around dry brush, twigs, cloth rags, or other flammable materials.
- Keep the engine at least 3 feet (1 meter) away from buildings or other structures.
- Keep the engine away from flammables and other hazardous materials (trash, rags, lubricants, explosives).

2. SAFETY PRECAUTIONS

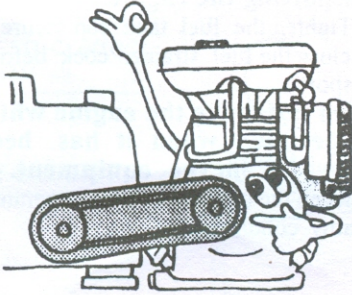

PROTECTIVE COVER

- Place the protective covers over the rotating parts.

If rotating parts such as the drive shaft, pulley, belt, etc. are left exposed, they are potentially hazardous.

To prevent injury, equip them with protective covers or shrouds.

- Be careful of hot parts.

The muffler and other engine parts become very hot while the engine is running or just after it has stopped.

Operate the engine in a safe area and keep children away from the running engine.

- Never make adjustments on the machinery while it is connected to the engine, without first removing the ignition cable from the spark plug.

Turning over the machinery by hand during adjusting or cleaning might start the engine, and machinery with it, causing serious injury to the operator.

- Never run the engine with governor disconnected, or operate at speeds in excess of 3600 rpm load.

SURROUNDINGS

- Operate the engine on a stable, level surface free of small rocks, loose gravel, etc.

Operate the engine on a level surface.

If the engine is tilted, fuel spillage may result.

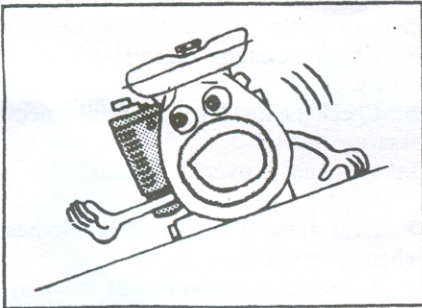

NOTE

Operating the engine at a steep incline may cause seizure due to improper lubrication even with a maximum oil level.

2. SAFETY PRECAUTIONS

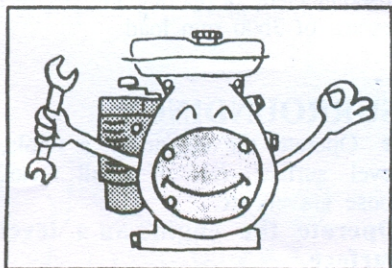
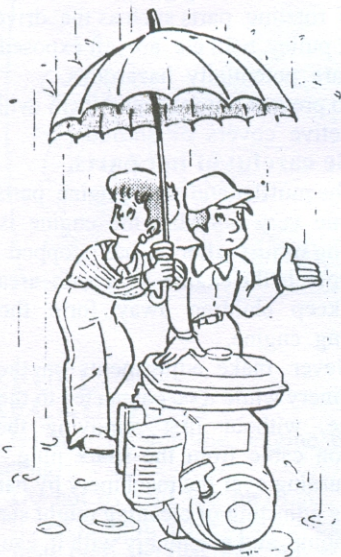

- **Be careful of fuel spillage when transporting the engine.**

Tighten the fuel tank cap securely and close the fuel strainer cock before transport.

- **Do not move the engine while in operation when it has been removed from the equipment.**
- **Keep the unit dry (do not operate it in rainy conditions).**

PRE-OPERATION CHECKS

- Carefully check fuel pipes and joints for looseness and fuel leakage. Leaked fuel creates a potentially dangerous situation.
- Check bolts and nuts for looseness. A loose bolt or nut may cause serious engine trouble.
- Check the engine oil and refill if necessary.
- Check the fuel level and refill if necessary. Take care not to overfill the tank.

- **Wear snug fitting working clothes when operating the engine.**

Loose aprons, towels, belt, etc. may be caught in the engine or drive train, causing a dangerous situation.

3. COMPONENTS

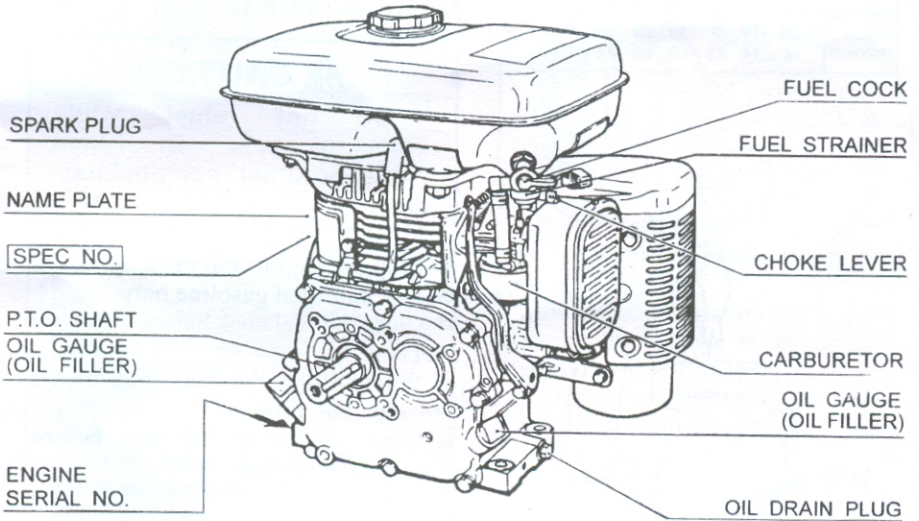
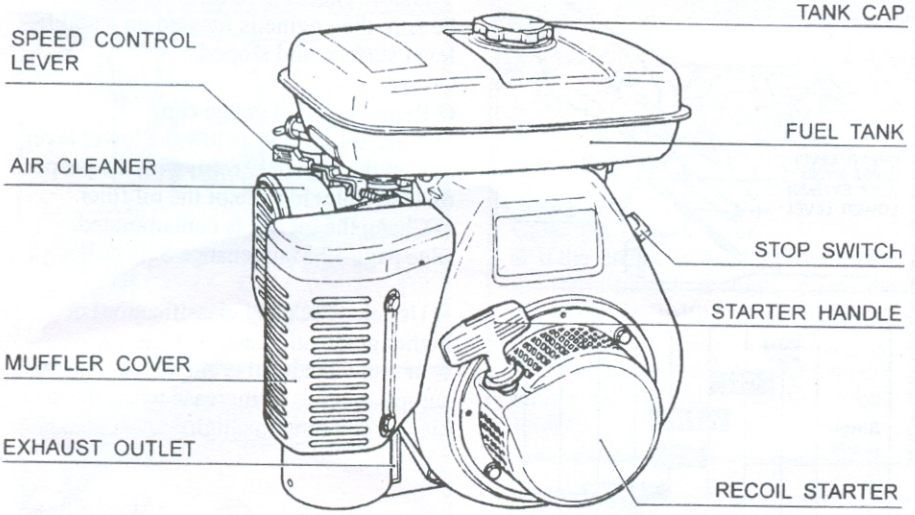

4. PRE-OPERATION CHECKS

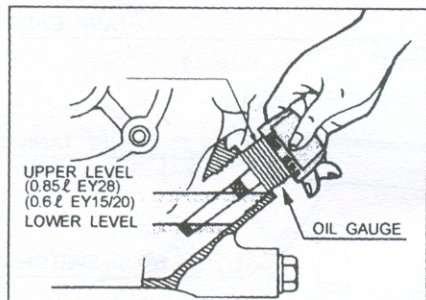

Single grade	5W						
	10W						
	20W						
	# 20						
	# 30						
Multi-grade	10W-30						
	10W-30						
Ambient temperature	-20	-10	0	10	20	30	40°C
	-4	14	32	50	68	86	104°F



CHECK ENGINE OIL

Before checking or refilling engine oil, be sure the engine is located on a stable, level surface and stopped.

- Remove the oil gauge cap.
- If the oil level is below the lower level line on the dipstick, refill with the proper oil (see table) to edge of the oil filler.
- Change the oil if it is contaminated. (See page 12 Maintenance Schedule.)
- Use class SC(API classification) or higher grade oil.
- If multi-grade oil is employed, oil consumption tends to increase when the ambient temperature is high.

CHECK FUEL

⚠ CAUTION

Do not refuel while smoking, near an open flame or other potential hazards.

- Stop the engine and open the cap.
- Use unleaded gasoline only.
- Close the fuel cock before filling the fuel tank.
- When filling the fuel tank, always use the fuel filter.
- Wipe off any spilled fuel before starting the engine.

5. OPERATING YOUR ENGINE

STARTING

STOP SWITCH

1

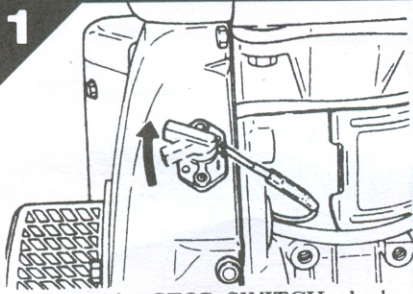

Turn the STOP SWITCH clockwise to the position "I".

CHOKE LEVER

4



Close the chocke lever.

- If the engine is warm or the ambient temperature is high, colse the choke lever half-way, or keep it open fully.
- If the engine is cold, or the ambient temperature is low, close the choke lever.

FUEL COCK

2

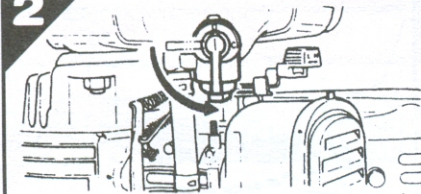

Open the fuel cock.

SPEED CONTROL LEVER

3

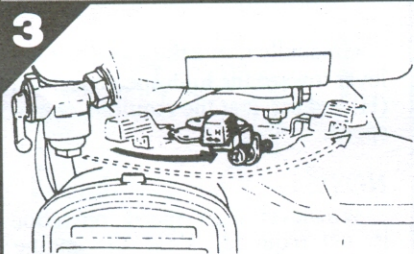

Set the speed control lever 1/3 of the way towards the high speed position.

RECOIL STARTER

5

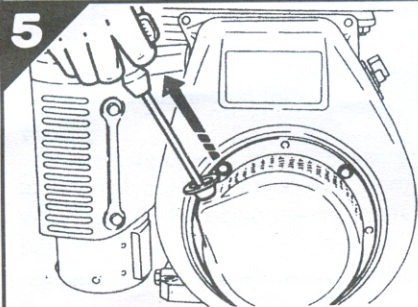

- Pull the starter handle slowly until resistance is felt. This is the "compression" point. Return the handle to its original position and pull swiftly.
- Do not pull out the rope all the way.
- After starting the engine, allow the starter handle to return to its original position while still holding the handle.

5. OPERATING YOUR ENGINE

RUNNING

CHOKE LEVER

6

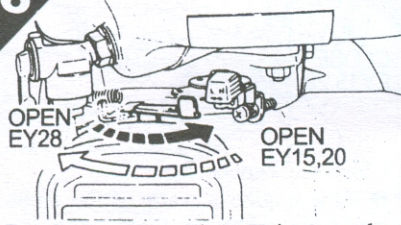

After starting the engine, gradually open choke by turning the choke lever and finally keep it open fully.

Do not fully open the choke lever immediately when the engine is cold or the ambient temperature is low, because the engine may stop.

SPEED CONTROL LEVER

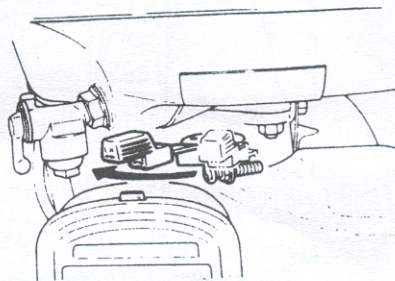

After the engine starts, set the speed control lever at the low speed position (L) and warm it up without load for a few minutes.

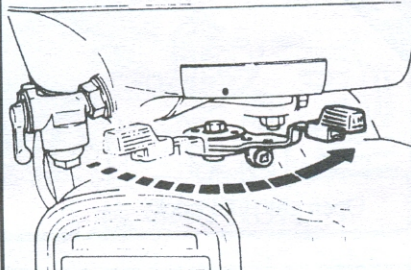

Gradually move the speed control lever toward the high speed position (H) and set it at the required engine speed.

NOTE :

Whenever high speed operation is not required, slow the engine down (idle) by moving the speed control lever to save fuel and extend engine life.

5. OPERATING YOUR ENGINE

STOPPING

SPEED CONTROL LEVER

1

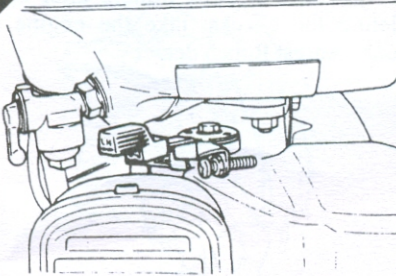

Set the speed control lever at the low speed position (L) and allow the engine to run at low speed for 2 or 3 minutes before stopping.

STOP SWITCH

2

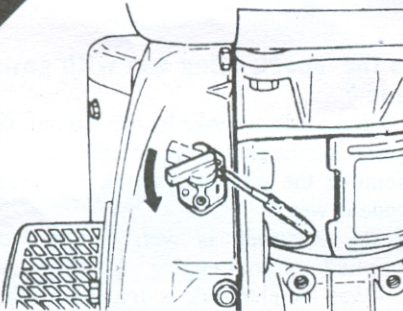

Turn the STOP SWITCH counter-clockwise to the position "O".

FUEL COCK

3

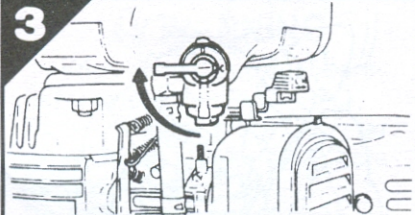

Close the fuel cock.

RECOIL STARTER

4

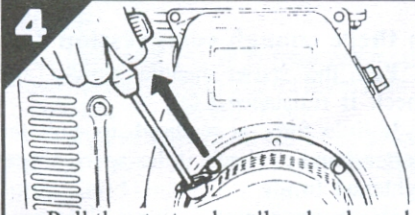

Pull the starter handle slowly and return the handle to its original position when resistance is felt.

NOTE :

The above operation is necessary to prevent outside moist air from intruding into the combustion chamber.

STOPPING ENGINE WITH THE FUEL COCK

Close the fuel cock and wait for a while until the engine stops.

Avoid to let the fuel remain in the carburetor over long periods, or the passages of the carburetor may become clogged with impurities, and malfunctions may result.

If your engine has an electric starter, set the key switch to the STOP position after stopping the engine.

6. EASY TROUBLESHOOTING



Is there enough compression ?

1. Pull the starter handle slowly and check if resistance is felt.
2. If little force is required to pull the starter handle, check if the spark plug is tightened firmly.
3. If the spark plug is loose, tighten it.



WHEN ENGINE WILL NOT START :

- Perform the following checks before you take the engine to your Roben dealer.
- If you still have trouble after completing the checks, take the engine to your nearest Roben dealer.



Is the spark plug wet with gasoline ?

1. Choke (close choke lever) and pull the starter handle five or six times. Remove the plug and check if its electrode is wet.
If the electrode is wet, fuel is well supplied to your engine.
2. When the electrode is dry, check where the fuel stops. (Check the fuel intake of the carburetor and fuel strainer intake.)
3. In case the engine does not start with well supplied fuel, try to use fresh fuel.

6. EASY TROUBLESHOOTING



1. Remove the plug and connect it to the plug cap.
Pull the starter handle while grounding spark plug against engine body.
2. Try with a new plug if the spark is weak or there is no spark.
3. The ignition system is faulty if there is no spark with a new plug.
Take your engine to your nearest Roben dealer.

Is there a strong spark across the electrode?

WARNING

Wipe out spilled fuel carefully before testing.
Place spark plug as far away from spark plug hole as possible.
Do not hold spark plug by hand while pulling recoil starter.

NOTE

Engine with the oil sensor will stop automatically when the oil level falls below the prescribed limit.
The engine can not be started unless the oil level is raised above the prescribed limit.

7. MAINTENANCE SCHEDULE

DAILY INSPECTION

Before running the engine, check the following service items.

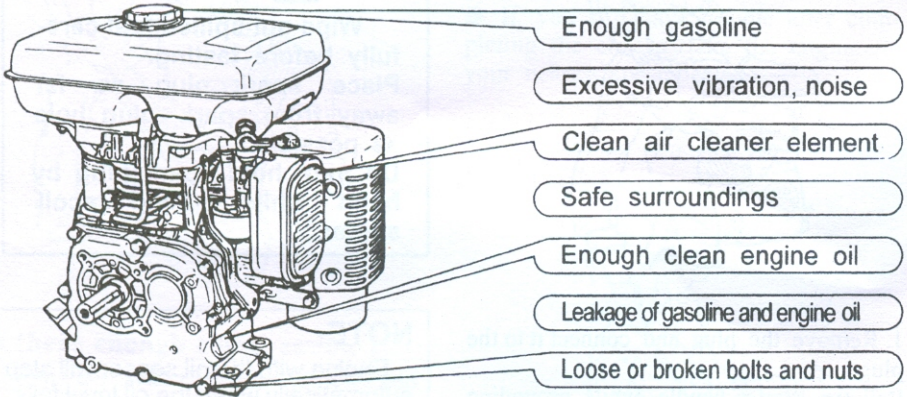

PERIODIC INSPECTION

Periodic maintenance is vital to the safe and efficient operation of your engine.

Check the table below for periodic maintenance intervals.

The following chart is based on the normal engine operation schedule.

	8 hours (daily)	50 hours (weekly)	200 hours (Monthly)	500 hours
CLEAN ENGINE AND CHECK BOLTS & NUTS	● (Daily)			
CHECK AND REFILL ENGINE OIL	● (Refill daily upper limit.)			
CHANGE ENGINE OIL	(Initial 20 hours)	●		
CLEAN SPARK PLUG		●		
CLEAN AIR CLEANER		●		
CLEAN FUEL STRAINER			●	
CLEAN AND ADJUST SPARK PLUG GAP			●	
CLEAN AND ADJUST CARBURETOR				●
CLEAN CYLINDER HEAD				●
ADJUST VALVE CLEARANCE				●
OVERHAUL ENGINE IF NECESSARY				●

8. "HOW-TO" MAINTENANCE

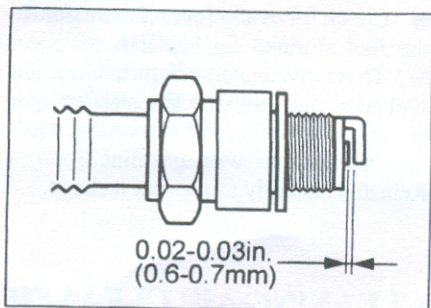

INSPECTING THE SPARK PLUG

- Clean off carbon deposits on the plug electrode using a plug cleaner or wire brush.
- Check electrode gap. Adjust gap 0.6mm to 0.7mm (0.02inch.-0.03inch.)
- Use a proper spark plug :



ENGINE OIL CHANGE

⚠ WARNING

Make sure the fuel cap is tightly secured to avoid spillage.

- Initial oil change
.....After 20 hours of operation
- Thereafter
.....Every 50 hours of operation



1. When changing oil, stop the engine and loosen the drain plug.
2. Re-install the drain plug before refilling oil.
3. Refer to the recommended oil table on page 5.
4. Always use the best grade and clean oil. Contaminated oil, poor quality oil and shortage of oil cause damage to engine or shorten the engine life.

8. "HOW-TO" MAINTENANCE

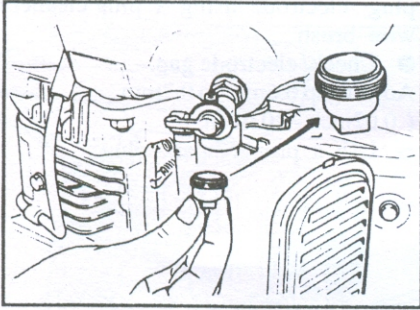

CLEANING FUEL STARIN-ER

- Check for water or contaminants in the fuel strainer.
 - To remove water and dirt, close the fuel cock and remove the strainer cup.
 - After removing dirt and water, wash the strainer cup with gasoline.
- Reinstall securely to prevent leakage.

CLEANING AIR CLEANER

Dirty air cleaner element will cause starting difficulty, power loss, engine malfunctions, and shorten engine life extremely.

Keep the air cleaner element clean.

● Urethane Foam Element

Remove the element and wash it in kerosene or diesel fuel. Then saturate it in a mixture of 3 parts kerosene and 1 part engine oil. Squeeze the element to remove the mixture and install it in the air cleaner.

● Urethane Foam Dual Structure

1. Clean the urethane foam in the same way as described above.
2. Wash the element in kerosene or diesel fuel. With the kerosene or diesel fuel still dripping off, saturate it in a mixture of 3 parts kerosene or diesel fuel and 1 part engine oil, wring the element to remove the mixture and install.

- If an oil bath or special air cleaner with pre-cleaner is used, clean the oil pan, fill oil to the required level or clean the dust pan.

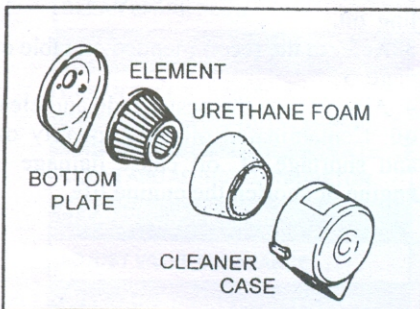
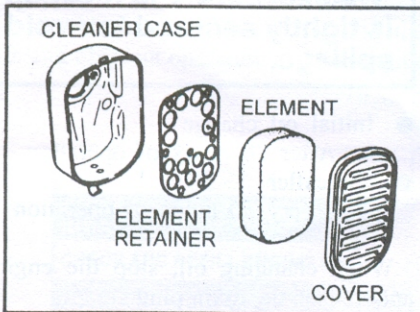

8. "HOW-TO" MAINTENANCE

CHECKING BOLTS, NUTS AND SCREWS

Retighten loose bolts and nuts.
Check for fuel and oil leaks.
Replace damaged parts with new ones.
Keep safety in your mind.

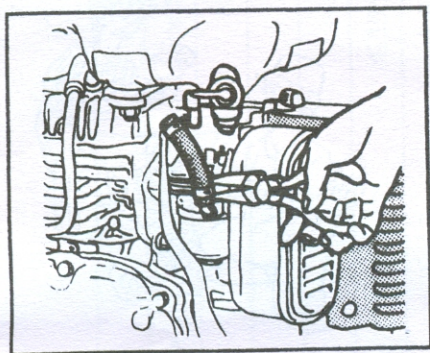
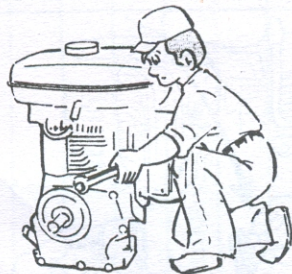

CHECK BATTERY

Refill the battery with distilled water,
If the electrolyte fluid is below level line.

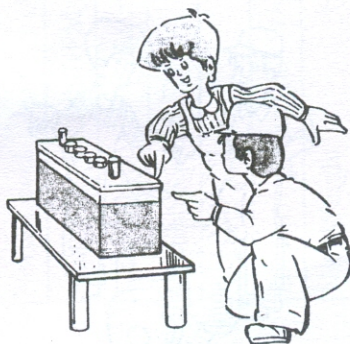

FUEL PIPE REPLACEMENT

Replace the fuel pipe every 2 years.
when fuel leak is found replace it immediately.

9. PREPARATIONS FOR STORAGE

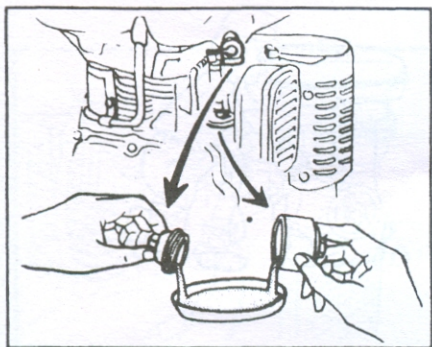

DISCHARGE FUEL (NO SMOKING !)

- Remove the strainer cup, place the strainer over a container and open the strainer cock to discharge fuel from the fuel tank.
- Remove the carburetor float chamber bolt from the bottom and discharge fuel from the carburetor.

OIL

- Change the used engine oil with fresh oil.
- Remove the spark plug, pour about 5 cc of engine oil into the cylinder, slowly pull the starter handle of the recoil starter 2 or 3 times, and re-install the spark plug.

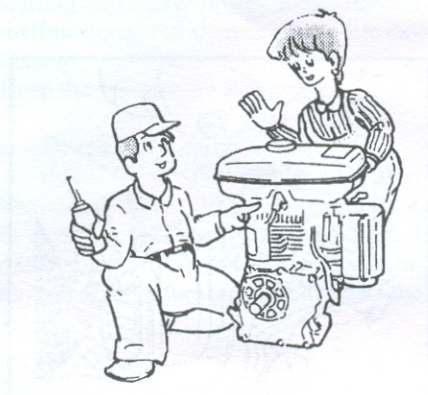

CLEAN AND STORE

- Slowly pull the recoil starter knob until resistance is felt and leave it in that position.
- Clean the engine thoroughly with an oiled cloth, put the cover on, and store the engine indoors in a well-ventilated, low humidity area.