

Portable Blower (Air Type)

(Made In Taiwan)

Main Elements:

1. Mesh cover
2. Screw
3. Propeller
4. Screw
5. Screw
6. Main case
7. Motor
8. Tube
9. Valve
10. Muffler

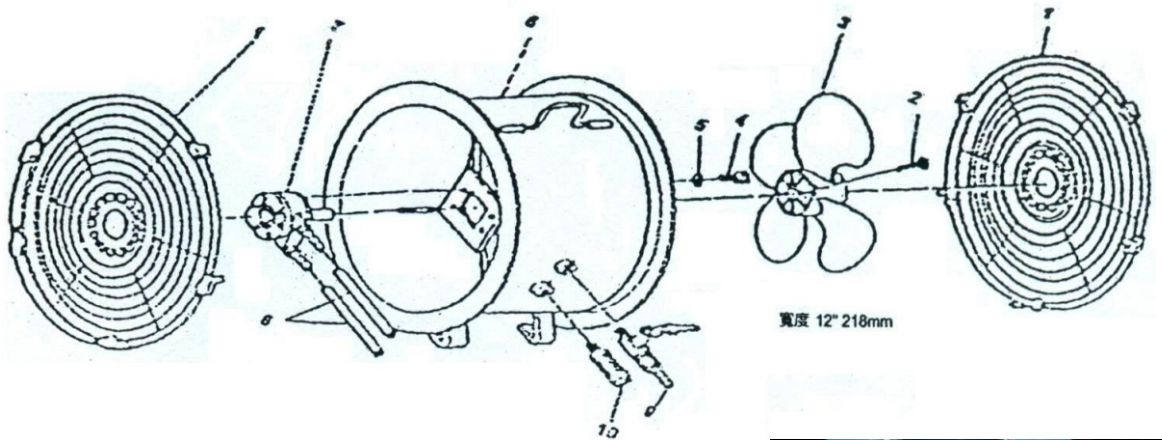

Power	: 3/4HP
Air flow	: 1200m ³ /h
Rotation Speed	: 2300rpm
Air Consumption	: 27cfm
Dimension(L x W x H)	: (400x240x415)mm
Interface Screw Hole Diameter	: Ø 6
Muffler Install Interface Size	: 1/4PTx82
Air Port Screw Size	: 2x2-1/4NPT
Working Pneumatic Pressure	: 4 ~ 5 kgf/cm ²

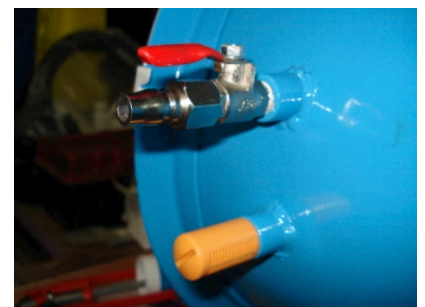

TR-12

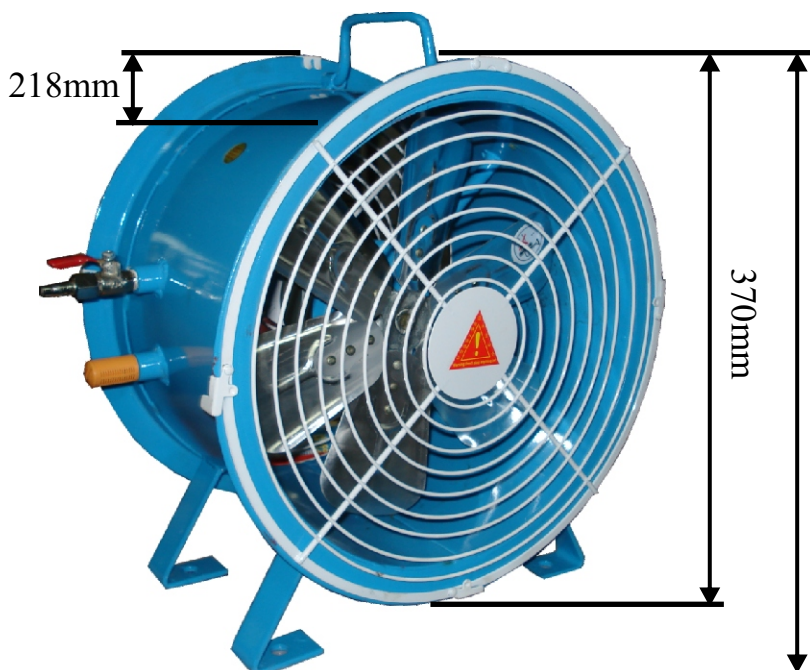

Stock Code :
880217004

***Product's specification may subject to change without further notice.
***Actual product may slightly differ from pictures shown.

ESM176
(21/12/09)